

SCAIM04-A-DW Safety AI-TC module

Safety I/O , Thermocouple input 7 ch + Cold junction compensation input 1 ch

■ Summary

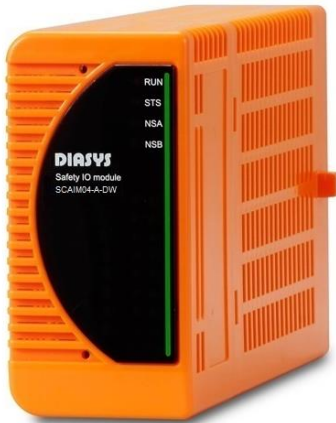

- * Number of input channels : 7 ch /Thermocouple input (Channel individual insulation)
1 ch /Cold junction compensation input (Channel individual insulation)
- * Thermocouple type : T/J/K/E
Switch : 2
- * User interface : (Front panel upper side : for H/W reset,
lower side : unused)
- * Module ambient temperature : -5 to 60°C
- * RTD type : Pt100 Ω
- * In compliance with Functional Safety Standard IEC 61508

SCAIM04-A-DW Safety AI-TC module

Safety I/O , Thermocouple input 7 ch + Cold junction compensation input 1 ch

■ Specifications

ITEM		SPECIFICATION	
Input	Number of channels	7 ch /Thermocouple input (Channel individual insulation) 1 ch /Cold junction compensation input (Channel individual insulation)	
	Range	TC	-14 to 80 mV (Full Scale) T: -200 to 400°C -5.603 to 20.872 mV J: -200 to 1200°C -7.890 to 69.553 mV E: -200 to 1000°C -8.825 to 76.373 mV K: -200 to 1372°C -5.891 to 54.886 mV
		Cold junction compensation input range	PT100: -10 to 100°C 96.09 to 138.51 Ω (Full Scale)
	Signal filter	-3 dB @ 100 Hz	
Safe state		Communication cutoff	
Absolute accuracy		0.1% FS @ 25°C	
Temperature drift		Less than ±100 ppm/°C (relative to full-scale) (@ -5°C to 60°C)	
CMRR(Common mode rejection ratio)		100 dB or more attenuation	
NMRR(Normal mode rejection ratio)		About 30 dB attenuation (In the case of first-order lag filter initial setting value 100 ms)	
Data refresh cycle		1 msec	
Data format		0.1°C step for input range	
AD conversion type		∑, Successive approximation register(SAR)	
Input filter		Software filter 0 to 65535 msec (All channel set together by 1 msec step)	
Isolation voltage		AC 500 V Internal circuit(CPU/FPGA) - I/O terminal DC 200 V I/O terminal - PE DC 200 V Between I/O channels	
User interface		Switch 2 (Front panel upper side: for H/W reset, lower side : unused)	
Self diagnosis		Redundant I/O circuit comparison check Redundant CPU comparison check Quadruplexed A/D converter comparison check ADC stuck check CRC check Diverse calculation check Data format check I/O signal range check Watchdog timer Communication timeout check Redundant voltage monitor Clock abnormal check Functional check of the abnormal communication signal TPFS(Temporal Programming Flow Supervision): Loss-of-function check for system timers LPFS(Logical Programming Flow Supervision): Loss-of-function check for logical programming flow Open-wire/short-circuit check (Detected as under-range)	
Protection	Electrical	Overvoltage protection Overcurrent protection Double-insulated	
	Safety Function	Accuracy for safety function : 1.0% FS @ -5°C to 60°C Abnormal communication signal cutoff	
Indicators		4 indicators: Power / Status / Network status A / Network status B	
Current consumption		156 mA	
Weight		Less than 300 g	
Size		152.5 mm (D) x 94 mm (H) x 46 mm (W) (Protrusions excluded)	
Certification body		TUV SUD	
Safety integrity level (IEC 61508-1)		SIL3	
EMC Zone (EN 61131-2)		B (Dedicated power distribution, rated voltage: 300 V or less)	
Overvoltage category (IEC 60664-1)		II (Energy-consuming equipment to be supplied from the fixed installation)	
IEC protection class (IEC 60204-1)		II (Double insulated)	
Isolation method		independent isolated channels	
Hot-swapping		Supported *However, depending on the field circuit and the application program	
Resolution		16 bit *Two types of AD converters are duplexed.	
Rated voltage		DC 24 V -15% +20% (The voltage supplied from the backplane)	
Environmental conditions	Module ambient temperature	(Operation) -5 to +60°C (Storage) -25 to +85°C	
	Module ambient humidity	(Operating / Storage) 0 to 95% RH (No condensation)	
Vibration		3.5 mm at 5 Hz to 8.4 Hz, 1 G at 8.4 Hz to 150 Hz	
Shock		15 G 11 ms	

About compliant module type

For compliant modules of this product, please refer to "Compliant backplane list (CGS-S9901-E-XX)".

For compliant modules of this product, please refer to "Compliant accessory connector list (CGS-S9902-E-XX)".

SCAIM04-A-DW Safety AI-TC module

Safety I/O , Thermocouple input 7 ch + Cold junction compensation input 1 ch

■ Supported standards/Supported directives

Certified standard	Year	Title
IEC 61508	2010	Functional safety of electrical/electronic/programmable electronic safety-related systems
EN 61131-2	2007	Programmable controllers - Part 2: Equipment requirements and tests
IEC 61131-6	2012	Programmable controllers - Part 6: Functional safety
IEC 61511-1	2004	Functional safety - Safety instrumented systems for the process industry sector - Part 1: Framework, definitions, system, hardware and software requirements,
EN 50156-1	2004	Electrical equipment for furnaces and ancillary equipment - Part 1 : Requirements for application design and installation
ISO 13849-1	2008	Safety of machinery - Safety-related parts of control systems-Part 1:General principles for design
EN 54-2	2007	Fire detection and fire alarm systems Part 2: Control and indicating equipment

Supported directive	Year	Title
RoHS	2011	DIRECTIVE 2011/65/EU OF THE EUROPEAN PARLIAMENT AND OF THE COUNCIL of 27 January 2011 on the restriction of the use of certain hazardous substances in electrical and electronic equipment
Low Voltage	2006	DIRECTIVE 2006/95/EC OF THE EUROPEAN PARLIAMENT AND OF THE COUNCIL of 12 December 2006 on the harmonisation of the laws of Member States relating to Electrical Equipment designed for use within certain voltage limits
EMC	2004	DIRECTIVE 2004/108/EC OF THE EUROPEAN PARLIAMENT AND OF THE COUNCIL of 15 December 2004 on the approximation of the laws of the Member States relating to electromagnetic compatibility and repealing Directive 89/336/EEC
Machinery	2006	DIRECTIVE 2006/42/EC OF THE EUROPEAN PARLIAMENT AND OF THE COUNCIL of 17 May 2006 on machinery, and amending Directive 95/16/EC



SCAIM04-A-DW Safety AI-TC module

Safety I/O , Thermocouple input 7 ch + Cold junction compensation input 1 ch

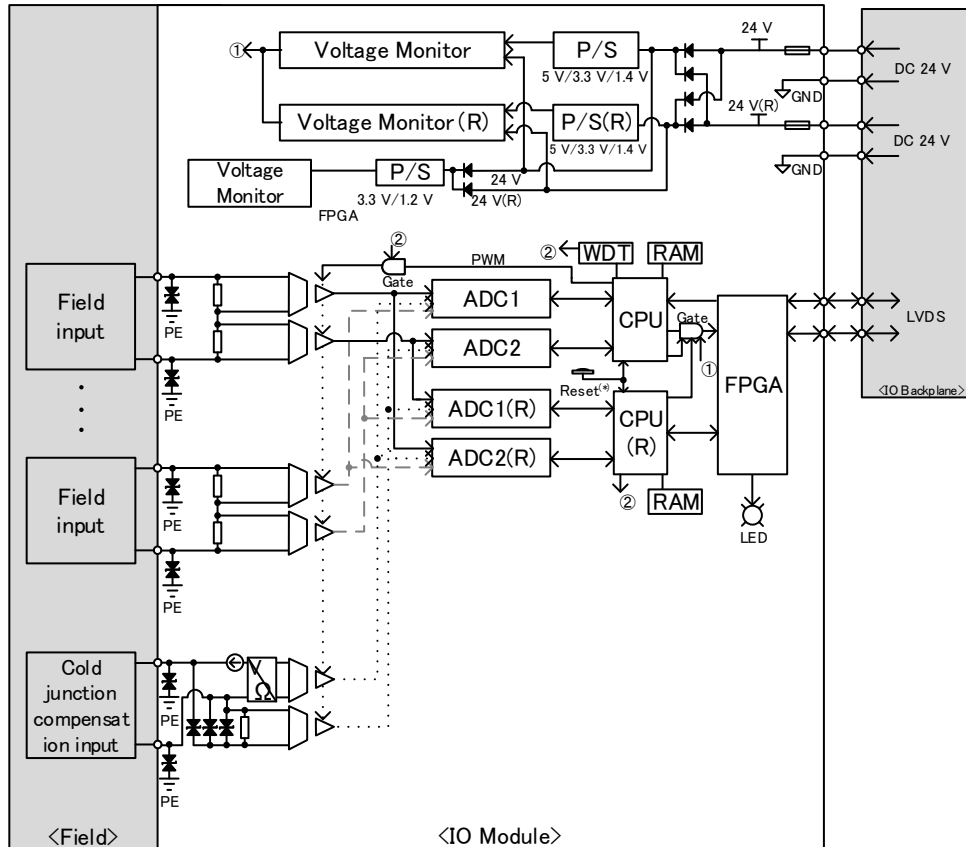
■ Block diagram



(*) Indicates the H/W reset switch on the upper side of the front panel.

(R)	:	Redundant
P/S	:	Power Supply
LVDS	:	Low Voltage Differential Signaling
FPGA	:	Field Programmable Gate Array
CPU	:	Central Processing Unit
RAM	:	Random Access Memory
WDT	:	Watch Dog Timer
ADC	:	Analog Digital Converter
PWM	:	Pulse Width Modulation
Gate	:	Buffer Gate
LED	:	Light Emitting Diode
GND	:	Ground
PE	:	Protective Earth
FS	:	Full Scale
BP	:	Backplane
	:	Resistor
	:	Fuse
	:	Zener diode

When using, please read the instruction manual attached to the product carefully and use it properly.

This catalog may not be distributed or reproduced in whole or in part without permission.

Please be aware that due to product improvements and modifications, the product description in this catalog may differ in certain respects from the actual product.

DIASYS Netmation/DIASYS Netmation4S is a registered trademark of Mitsubishi Heavy Industries, Ltd.

The service names and product names of other companies described in this catalog are the trademarks or registered trademarks of each company.